



LINON HOME DECOR PRODUCTS, INC.

ASSEMBLY INSTRUCTIONS

HALL TREE WITH STORAGE BENCH

PATÈRE AVEC BANC COFFRE

PERCHERO CON BANCO BAÚL

#84017WALC-01-KD-U

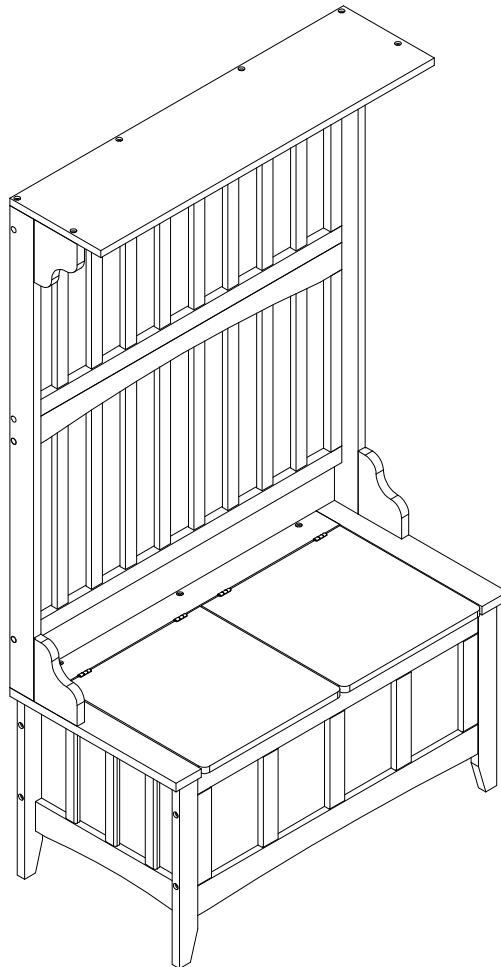

We are here to help ! Before you rerurn it - contact us !

We do our best to insure that your furniture arrives in excellent condition. In the event that a part is damaged or missing, Linon Home Decor will be happy to provide you with replacement parts, at no charge, within 30 days of purchase, providing the parts are available in our warehouse and the item purchased is part of our current inventory. In order to recieve spare parts, at no charge, you must provide proof of purchase within 30 days.

If you need assistance with assembly or replacement parts, please call Linon Customer Service, prior to returning the item to the store.

Our office is open Monday- Friday 9AM-5PM, Eastern Standard Time.

Our toll free customer service number is: 1-800-262-1852.

Or visit our web site WWW.LINON.COM to order spare parts and for care instructions on your newly purchased furniture.

V18-88579

- 1 -



HARDWARE IDENTIFICATION:

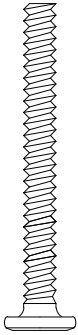

A x 08
(Ø1/4" x 2-1/2"L)

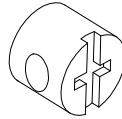

B x 08
(Ø1/4" x 1/2"L)

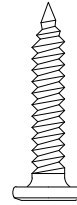

C x 18
(Ø1/4" x 1-1/2"L)

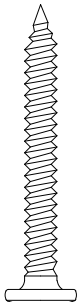

D x 03
(Ø1/4" x 2"L)

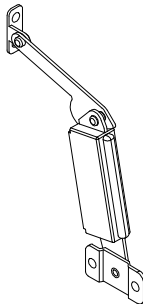

E x 01

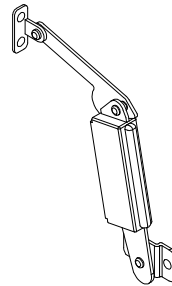

F x 01

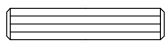

G x 29
(Ø5/16" x 1-3/16"L)



H x 04

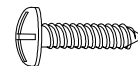

I x 16
(#3.5 x 5/8"L)



HARDWARE IDENTIFICATION:

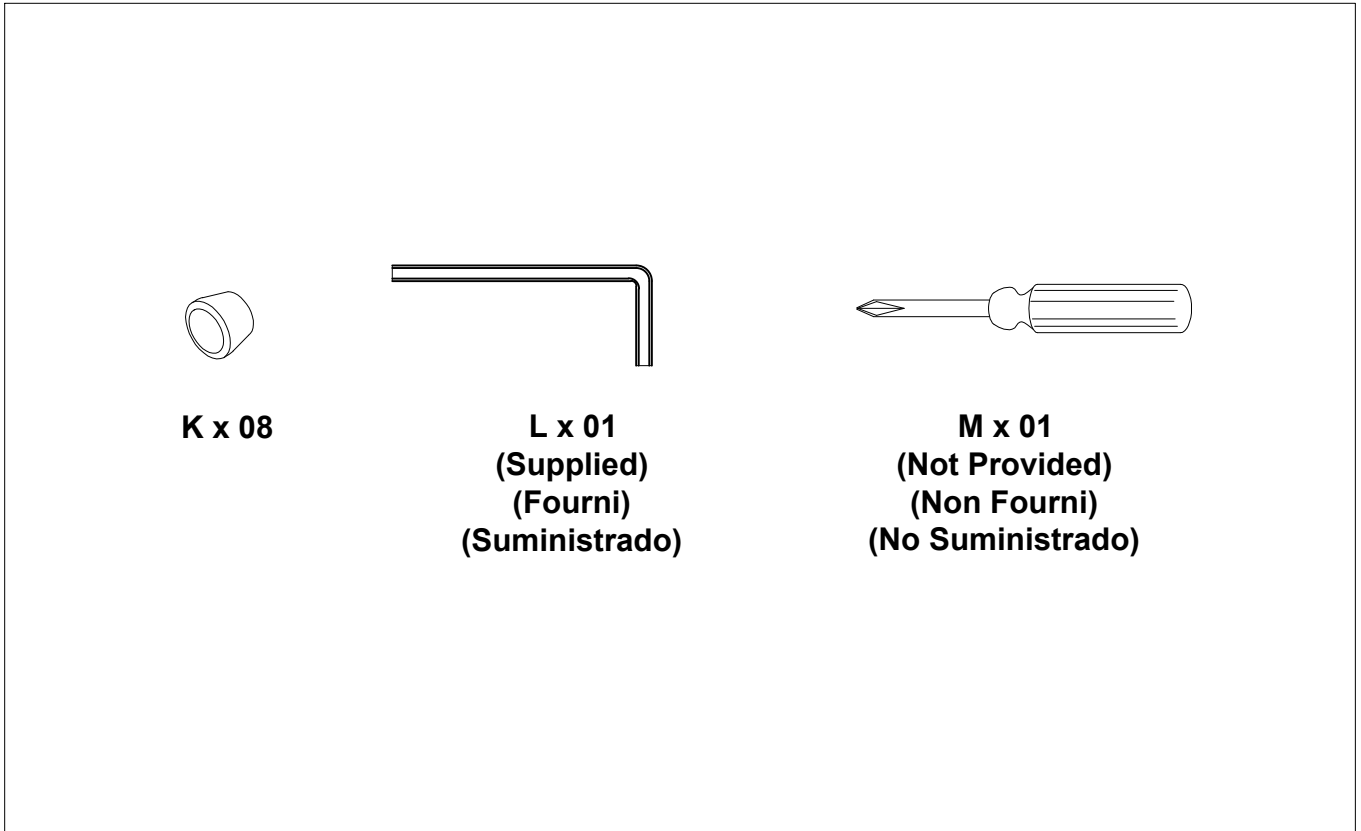

PART IDENTIFICATION:

PARTS	DESCRIPTION	QTY
#1	SEAT	01
#2	LEFT SIDE FRAME	01
#3	RIGHT SIDE FRAME	01
#4	BACK FRAME	01
#5	FRONT FRAME	01
#6	BOTTOM PANEL	01
#7	LEFT SIDE RAIL	01
#8	RIGHT SIDE RAIL	01
#9	TOP PANEL	01
#10	UPPER BACK FRAME	01
#11	LOWER BACK FRAME	01



PART IDENTIFICATION:

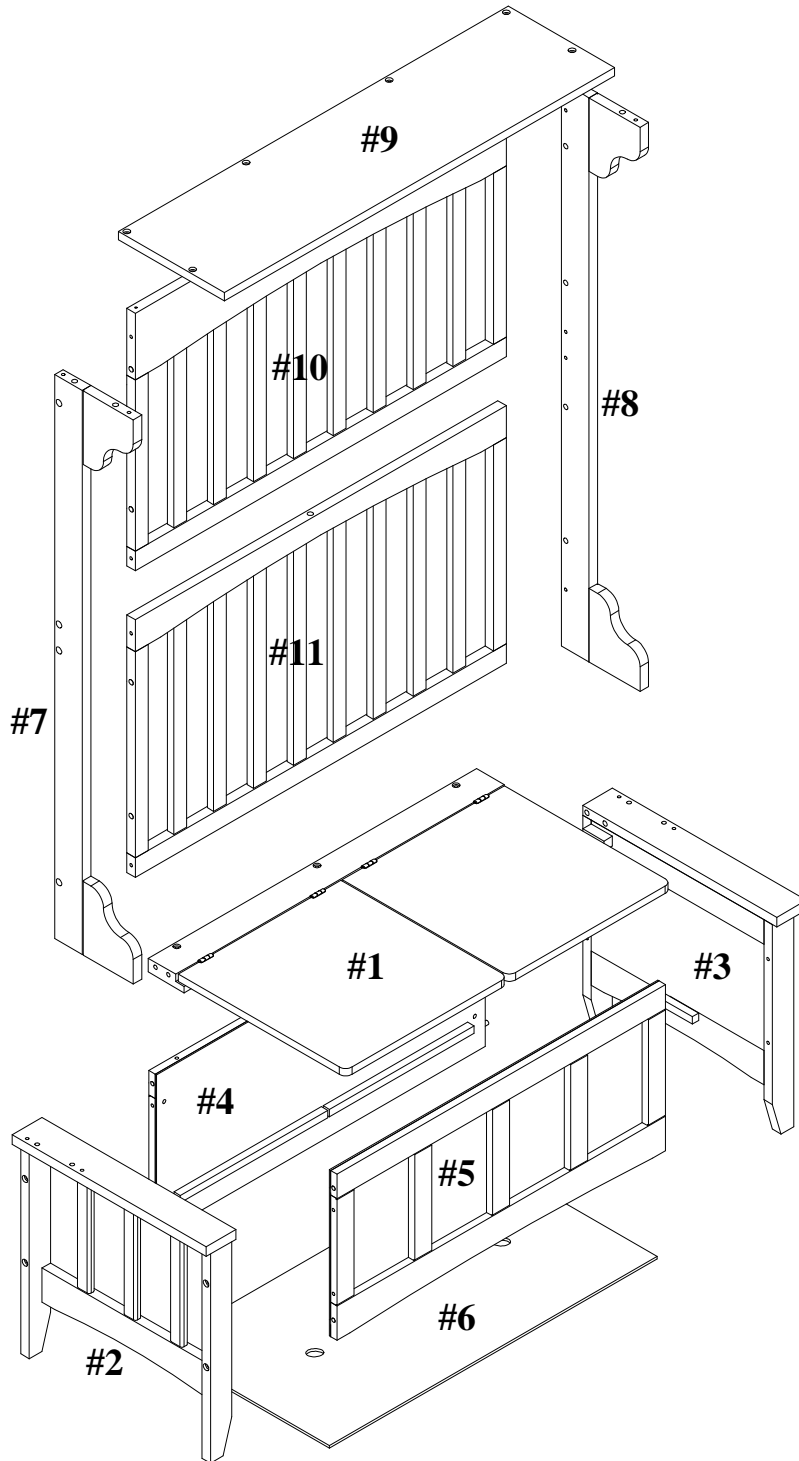



IMPORTANT: - Do not tighten bolts completely until all bolts are completely lined up and inserted into holes/nuts.

- Do not over tighten bolts to avoid stripping.

IMPORTANT: - Ne serrez pas complètement les boulons jusqu'à ce qu'ils soient bien alignés et insérés dans les trous et les écrous.





- Ne serrez pas excessivement les boulons pour éviter d'érafler la surface.

IMPORTANT: - No apriete completamente los pernos hasta que estén bien alineados e insertados en los orificios y las tuercas.

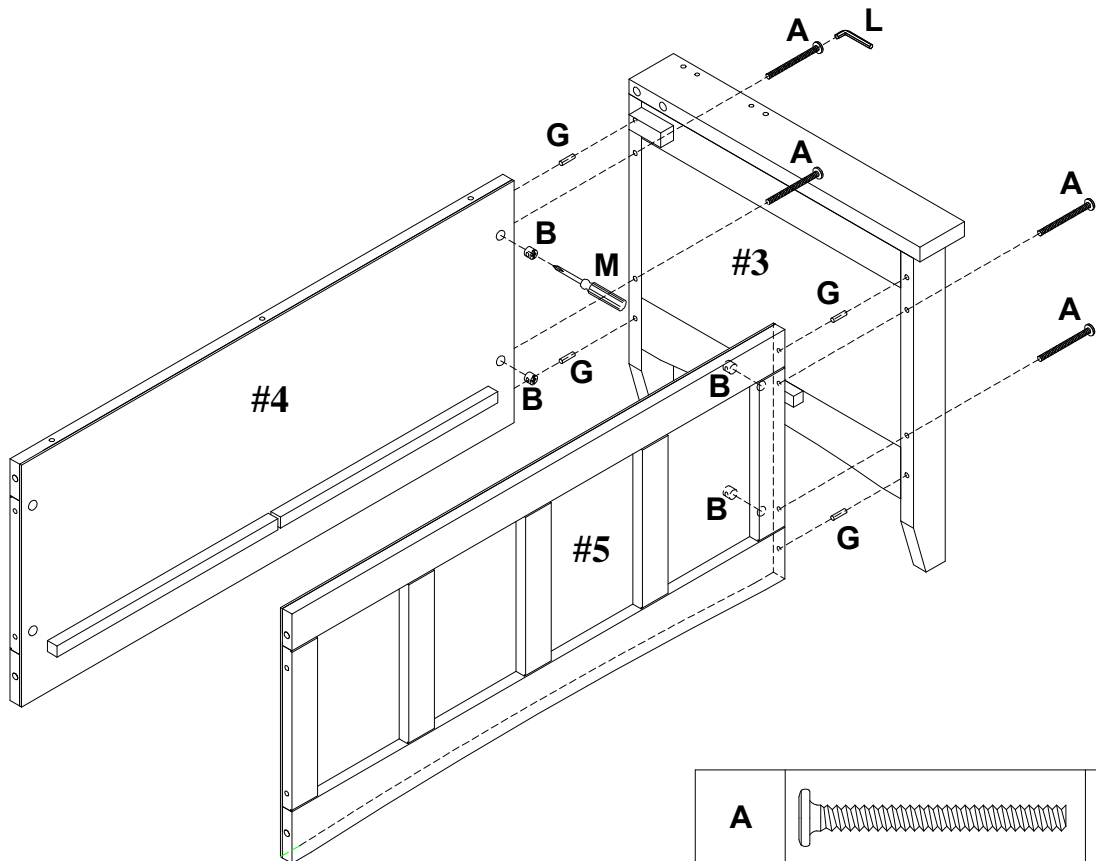
- No apriete exageradamente los pernos para evitar dañar el recubrimiento.

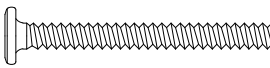
1.

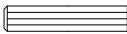

A		04
B		04
G		04
L		01
M	 (Not Provided)	01



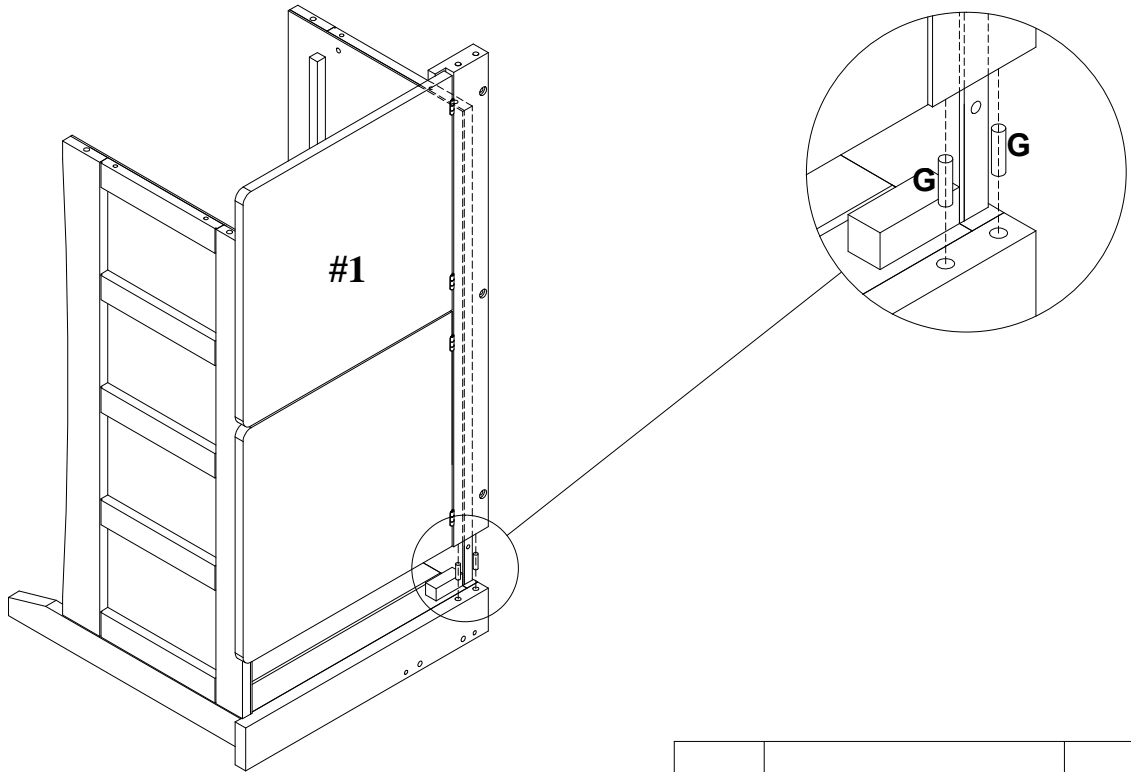

2.

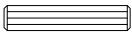

G		02
---	---	----

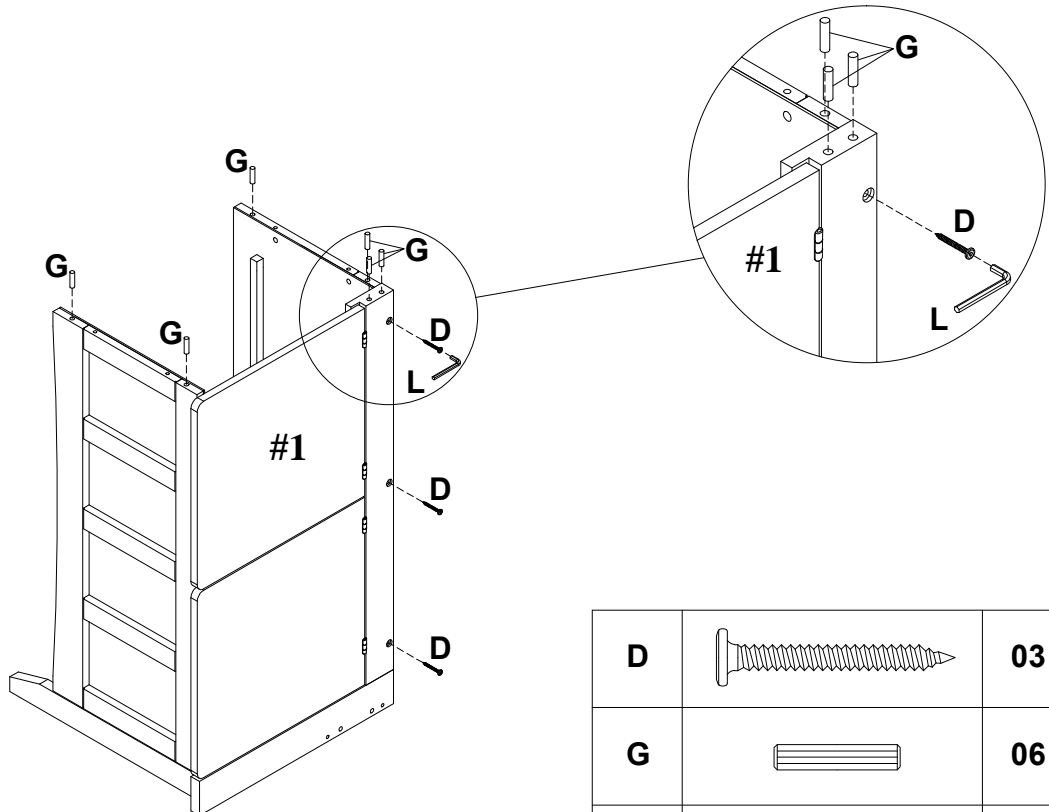
3.

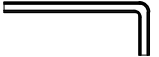

D		03
G		06
L		01



4.

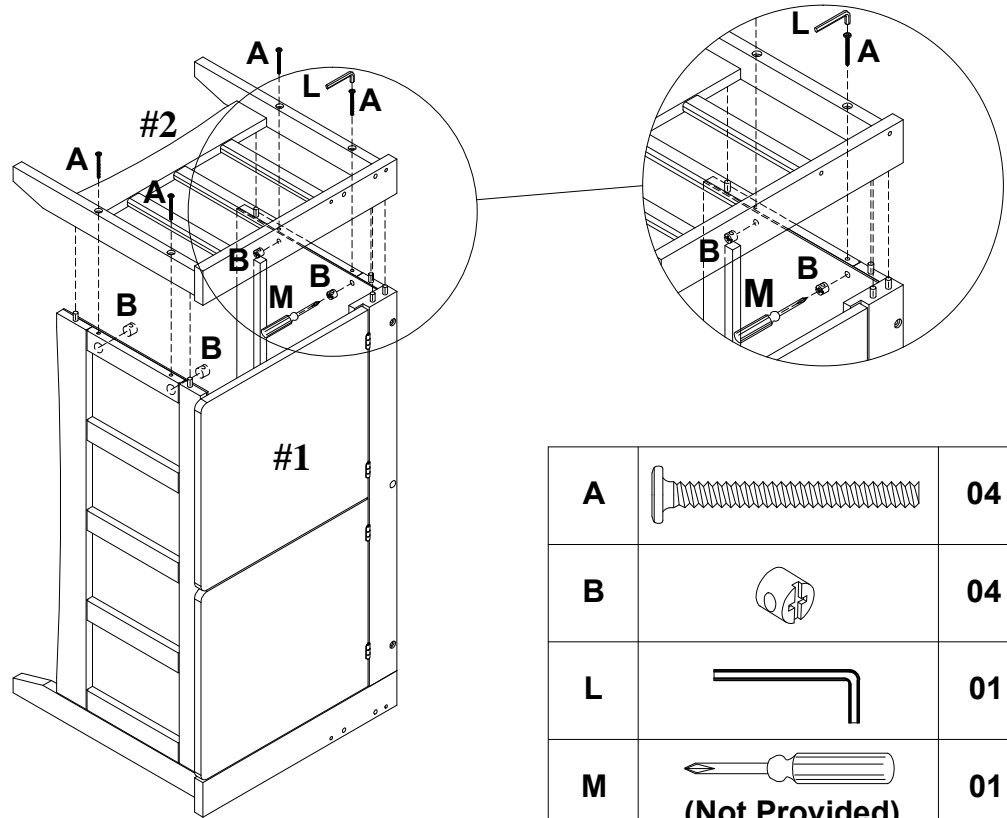

A		04
B		04
L		01
M	 (Not Provided)	01

5.

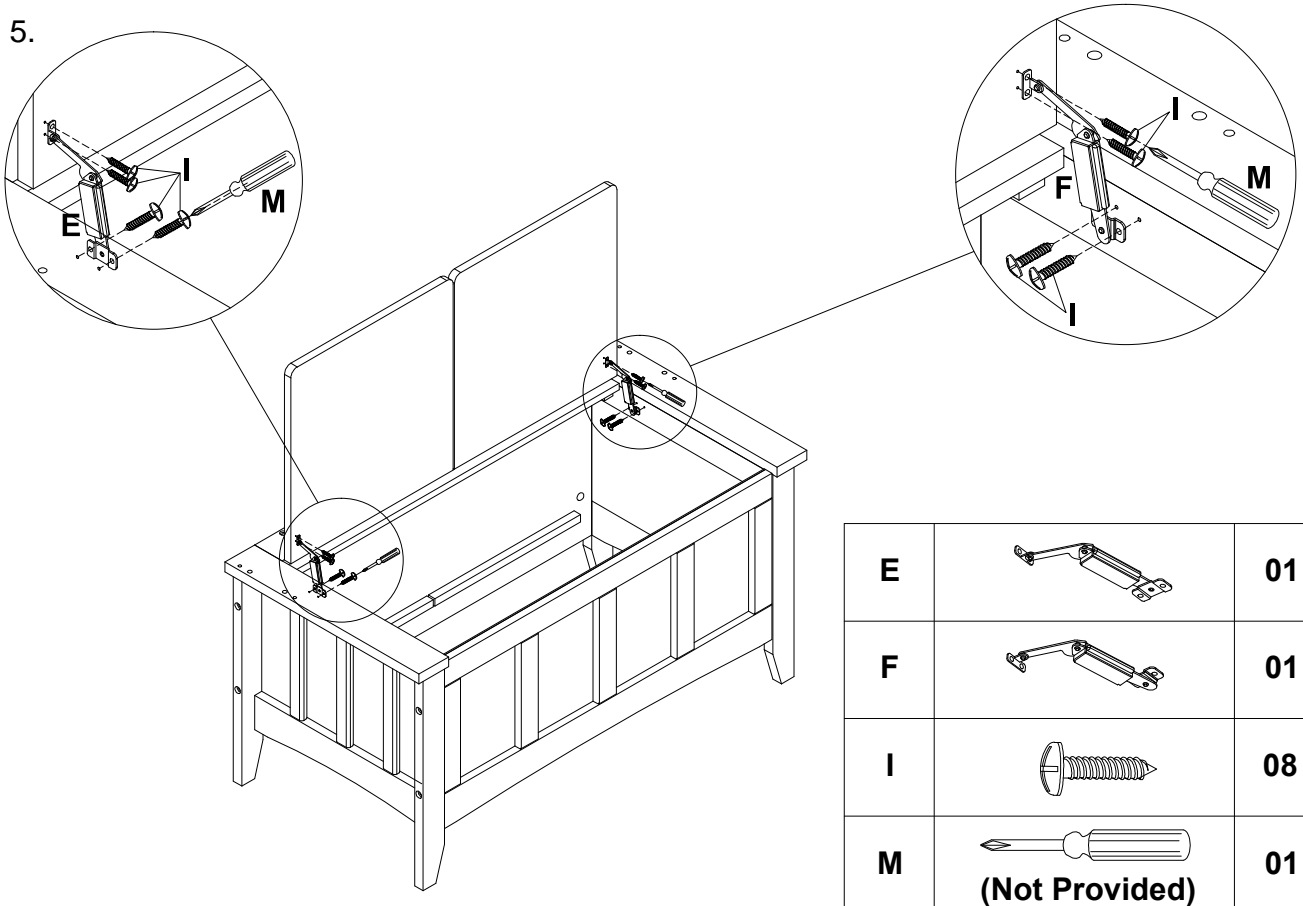

E		01
F		01
I		08
M	 (Not Provided)	01



6.

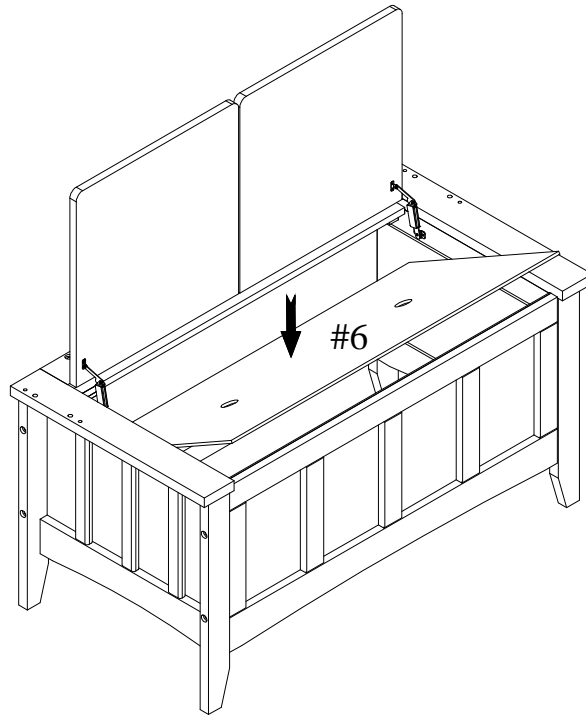

7.

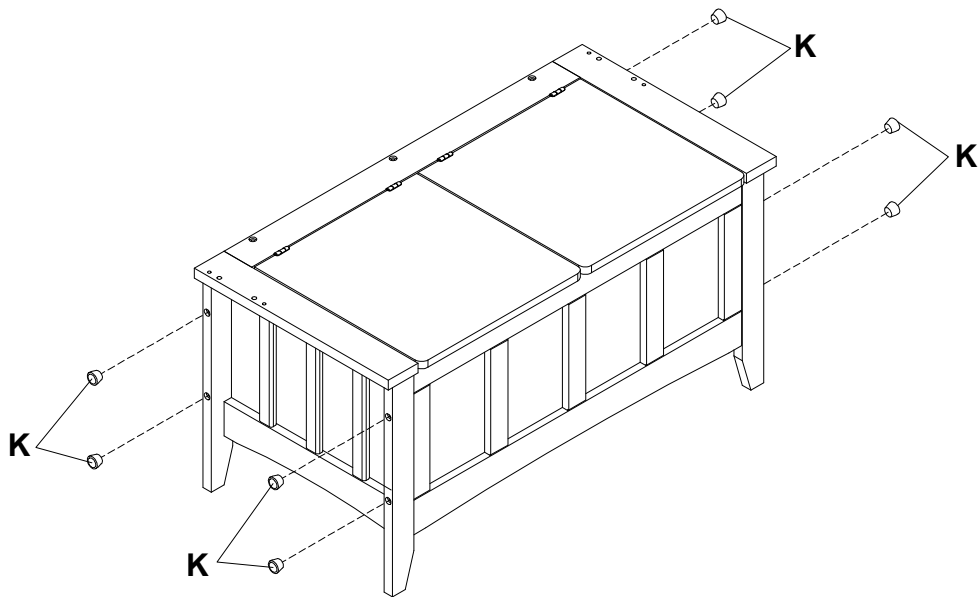

K



08



8.

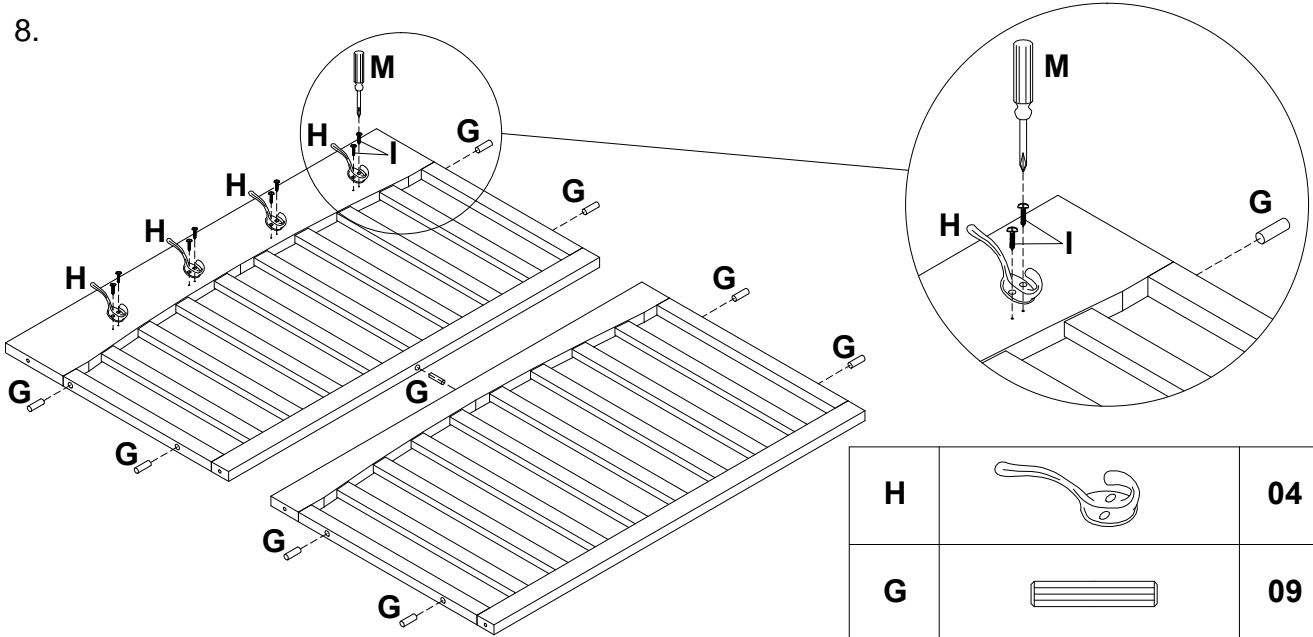

H		04
G		09
I		08
M	 (Not Provided)	01

9.

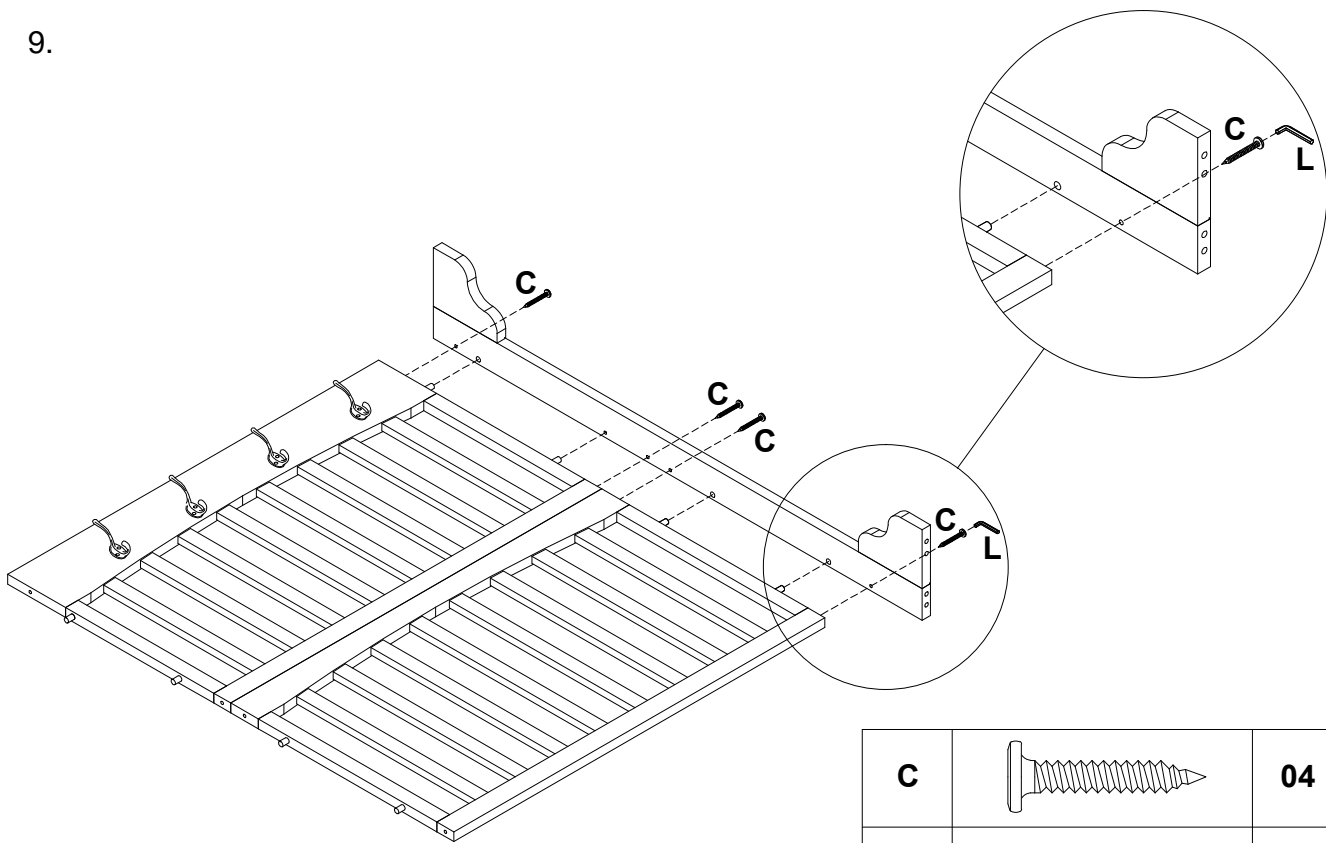

C		04
L		01



10.

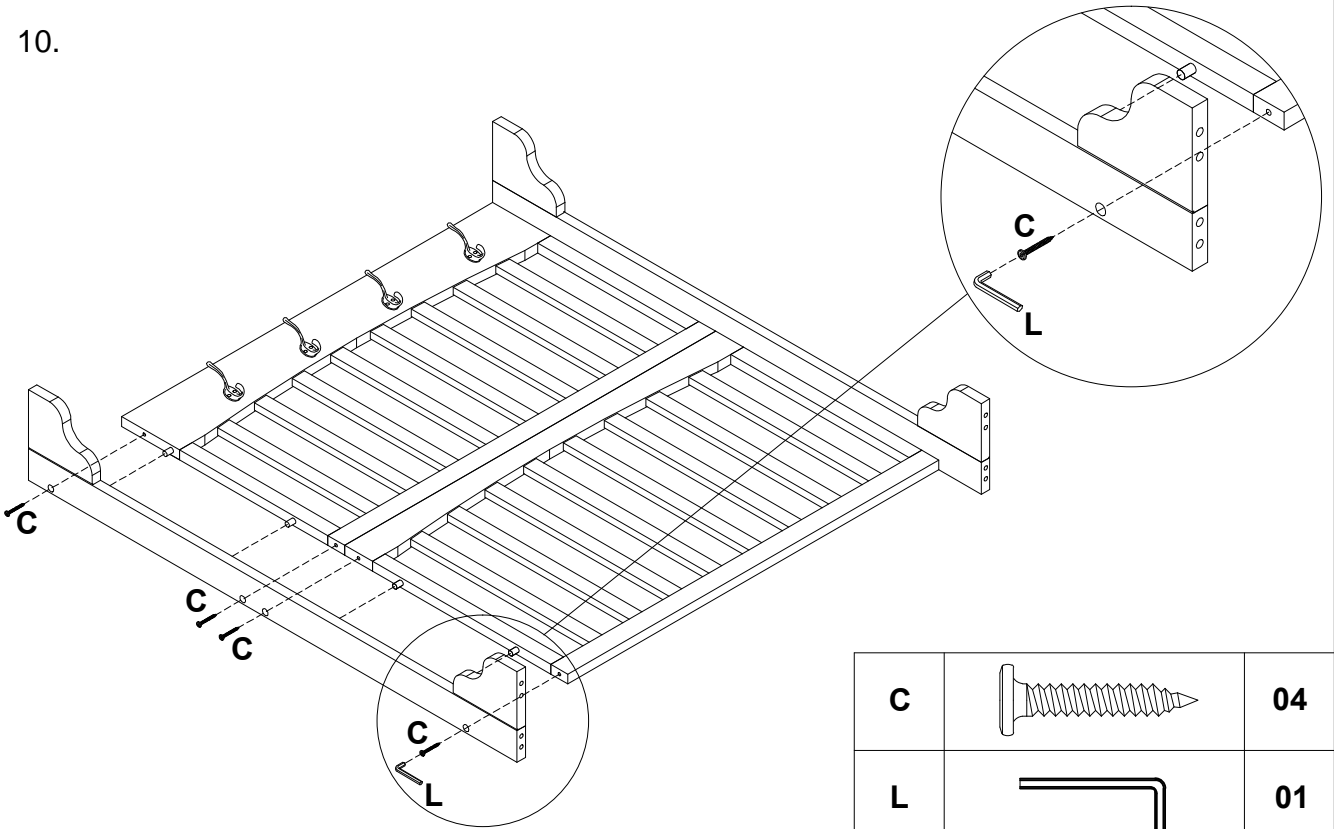

C		04
L		01

11.

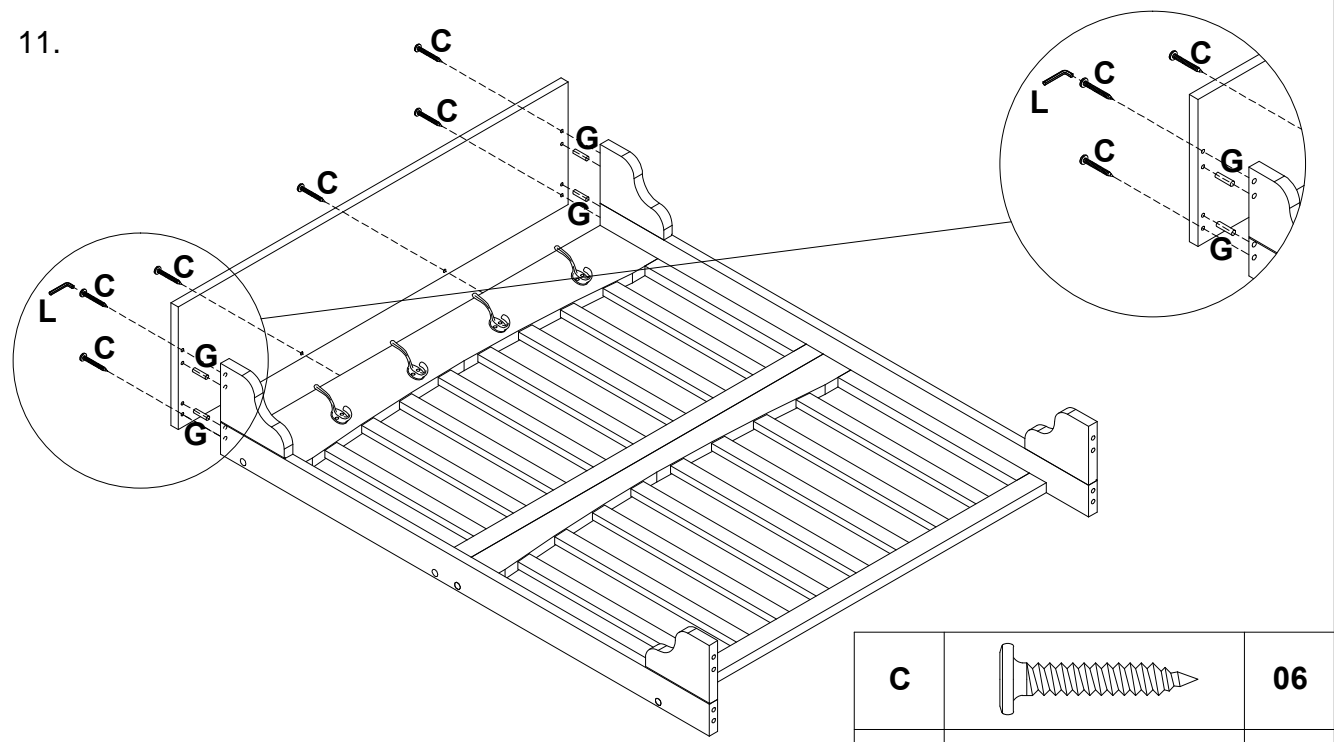

C		06
G		04
L		01



12.

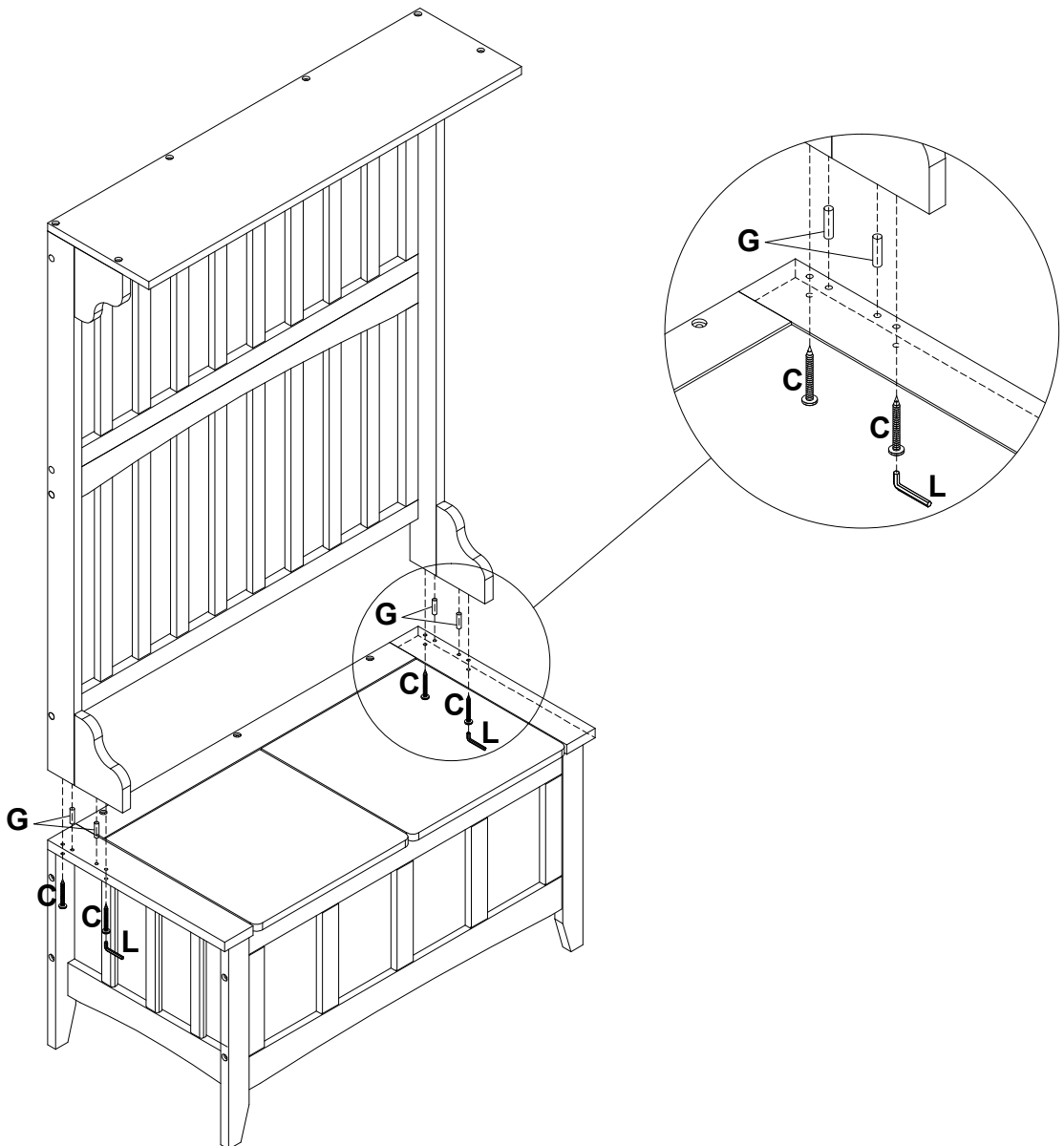

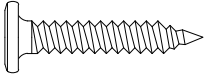
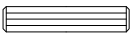
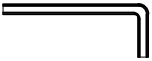
C		04
G		04
L		01



COMPLETED ASSEMBLY

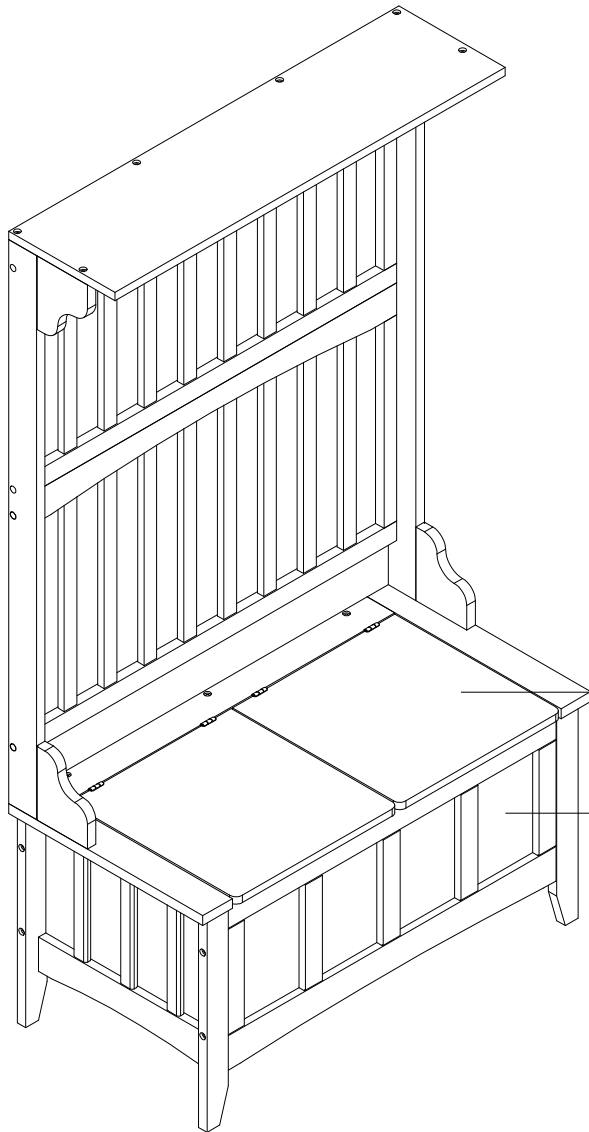

WEIGHT LIMITS

- SEAT: 275 LBS
- COUVERCLE: 275 LBS
- CUBIERTA: 275 LBS

- STORAGE BOTTOM: 30 LBS
- COFFRE: 30 LBS
- BAÚL: 30 LBS



LIMITED 6 MONTHS WARRANTY GARANTIE LIMITÉE DE 6 MOIS GARANTÍA LIMITADA DE 6 MESES

WHAT IS COVERED

This product is covered under our manufacturer's 6 months limited warranty (Linon Home Décor Products). To ensure your complete satisfaction, this warrants to the original purchaser that the Linon supplied item is free from defects in material and workmanship, as of the date of purchase, and that it will under normal use and proper care, remain so for six months after the date of purchase.

Replacement of missing or initially defective parts will be sent, at no charge, for a period of 30 days from the date of purchase with valid proof of purchase providing the parts are available in our warehouse and the item purchased is part of our current inventory.

WHAT IS NOT COVERED

It remains the customer's responsibility for freight and packaging charges to and from the customer service center. Labor and material charges to remove or replace parts under this warranty are not covered.

This warranty does not cover: Furniture used for commercial purposes, failures caused by improper installation assemble or by improper care, unreasonable or abusive use, freeze damage, acts of God, rust, purchased parts or return freight and packaging charges. Proof or purchase (dated register receipt) is required for this warranty claims.

HOW TO OBTAIN SERVICE

For further information, please contact our customer service department, c/o Linon Home Décor Products, Inc., between 9:00 AM and 5:00 PM Eastern Standard Time, Monday through Friday:

CUSTOMER SERVICE DEPARTMENT:

- 1) Email address:
consumersupport@linon.com
- 2) Toll free number:
1 - 800 - 262 - 1852

#84017WALC-01-KD-U

MADE IN VIETNAM
FABRIQUÉ AU VIETNAM
HECHO EN VIETNAM

(V18-88579)

QU'EST-CE QUI EST COUVERT

Ce produit est couvert sous une garantie limitée de 6 mois offerte par le fabricant. Afin d'assurer votre entière satisfaction, cela garantit à l'acheteur original que le produit fourni est exempt de défauts de matériaux et de fabrication à compter de la date d'achat, et ce, sous des conditions d'utilisation normales et de soins adéquats, valide pendant six mois après la date d'achat.

Le remplacement de pièces manquantes ou défectueuses dès le départ sera envoyé, sans frais, pour une période de 30 jours suivant la date d'achat avec une preuve d'achat valide pourvu que les pièces soient disponibles dans notre entrepôt et que l'article acheté fait partie de notre inventaire actuel.

QU'EST-CE QUI N'EST PAS COUVERT

Il y va de la responsabilité du client de ouvrir les frais de transport et d'emballage vers et à partir du centre de service après-vente. Les frais de la main-d'œuvre et des matériaux pour retirer les pièces ou les remplacer sous cette garantie ne sont pas couverts.

Cette garantie ne couvre pass: les meubles utilisés à des fins commerciales, les défaillances causées par un mauvais assemblage ou entretien (sans dépasser les limites de poids). l'utilisation déraisonnable ou abusive, les dommages causés par le gel, la rouille, les frais de transport et d'emballage pour des pièces achetées ou retournées. Une preuve d'achat (reçu de caisse daté) est requise pour les réclamations sous garantie.

COMMENT FAIRE POUR OBTENIR DU SERVICE

Pour de plus amples renseignements, veuillez communiquer avec notre département du service à la clientèle, entre 9h et 17h HNE, du lundi au vendredi.

CENTRE DE SERVICE À LA CLIENTÈLE:

- 1) Adresse de courriel:
consumersupport@linon.com
- 2) Numéro de téléphone sans frais:
1 - 800 - 262 - 1852

QUÉ ESTÁ CUBIERTO

Este producto está cubierto por la garantía limitada de 6 meses de nuestro fabricante. Para asegurar su total satisfacción, ésta garantiza al comprador original que el artículo proporcionado se encuentra libre de defectos materiales y de fabricación, a partir de la fecha de compra, y que permanecerá en tal estado, sometido a un uso normal y cuidados adecuados, durante los seis meses posteriores a la fecha de la compra.

Las partes faltantes o que presenten defectos al inicio de ese período de tiempo serán enviadas sin cargo, durante un lapso de 30 días a partir de la fecha de compra, mediante la presentación de un comprobante de compra válido, siempre que las partes estén disponibles en nuestro almacén y el artículo adquirido sea parte de nuestro inventario actual.

QUE' NO ESTÁ CUBIERTO

El cliente asumirá los costos de flete y empaque hacia y desde el centro de servicio de cliente. Los cargos de material y mano de obra para extraer o mreeemplazar partes en el marco de la ganranτία no están cubiertas.

Esta garantía no cubre: muebles utilizados con fines comerciales, fallas causadas por montaje de instalación inadecuados o uso indebido (se recomienda no exceder los límites de peso), uso no razonable o abusivo, daños por congelación, oxidación, partes compradas, flete de devolución y cargos de empaque. Se exigirá el comprobante de compra (la factura de registro con fecha) para hacer valer la garantía.

CÓMO OBTENER SERVICIO

Si desea más información, póngase en contacto con nuestro departamento de servicio al cliente, de lunes a viernes entre las 9:00 am. y las 5:00pm, hora estándar de los Estados Unidos.

DEPARTAMENTO DE SERVICIO AL CLIENTE:

- 1) Correo electrónico:
consumersupport@linon.com
- 2) Número telefónico gratuito:
1 - 800 - 262 - 1852

▲ WARNING

Serious or fatal crushing injuries can occur from furniture tipover. To help prevent tip-over:

- Install tipover restraint provided.
- Place heaviest items in the lower drawers.
- Unless specifically designed to accommodate, do not set TV's or other heavy objects on the top of this product.
- Never allow children to climb or hang on drawers, doors, or shelves.
- Never open more than one drawer at a time (OR).
- Do not defeat or remove the drawer interlock system.

Use of tipover restraints may only reduce, but not eliminate, the risk of tipover.

This is a permanent label. Do not remove!

▲ AVERTISSEMENT

Le basculement du meuble peut causer de graves blessures par écrasement, voire la mort. Pour empêcher le basculement :

- Installer les dispositifs antibasculement fournis.
- Ranger les articles les plus lourds dans les tiroirs du bas.
- À moins qu'il ne soit conçu à cette fin, éviter de placer un téléviseur ou un objet lourd sur le dessus de ce meuble.
- Ne jamais permettre à des enfants de monter sur les tiroirs, portes ou tablettes, ni de s'y suspendre.
- Ne jamais ouvrir plus d'un tiroir à la fois.
- Ne pas altérer ni retirer le système de verrouillage du tiroir.

L'utilisation d'un dispositif antibasculement ne peut que diminuer, et non éliminer, le risque de basculement. Cette étiquette est permanente. Ne pas tenter de l'enlever!

▲ ADVERTENCIA

El vuelco del mueble puede causar lesiones por aplastamiento e incluso la muerte. Para evitar que el mueble se vuelque:

- Instale los dispositivos antivuelco proporcionados.
- Guarde los artículos más pesados en los cajones inferiores.
- Evite colocar un televisor o un objeto pesado encima del mueble, salvo si éste último ha sido diseñado específicamente para dicho fin.
- No permita que los niños suban sobre los cajones, las puertas o los estantes ni que se cuelguen de dichas piezas.
- No abra más de un cajón a la vez.
- No altere ni quite el sistema de cerradura del cajón.

El uso de un dispositivo antivuelco sólo disminuye el riesgo de vuelco, no lo elimina.

Esta etiqueta es permanente. No trate de quitarla!



Strap
A (2pcs)



Flat Washer
B (4pcs)



Wall Anchor
C (2pcs)



Short Screw
D (2pcs)



Long Screw
E (2pcs)

Step 1: Attach strap (A) & flat washer (B) to the back of the product with short screw (D).

PLEASE NOTE: For your safety, to prevent the danger of this unit tipping over, it is important that the wall anchors are properly attached.

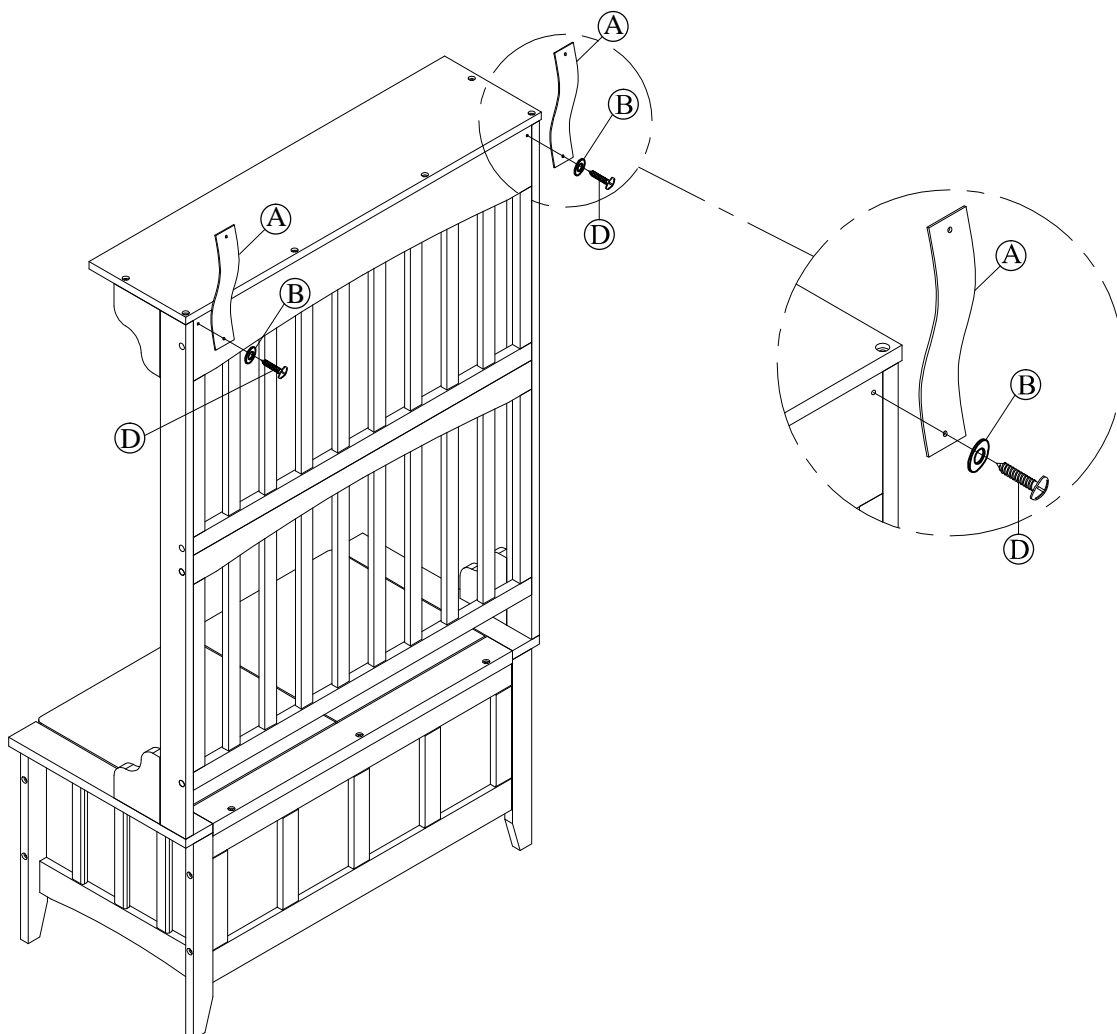

Step 2 : Put wall anchor (C) into the wall , attach strap (A) and flat washer (B) to the wall with long screw (E).

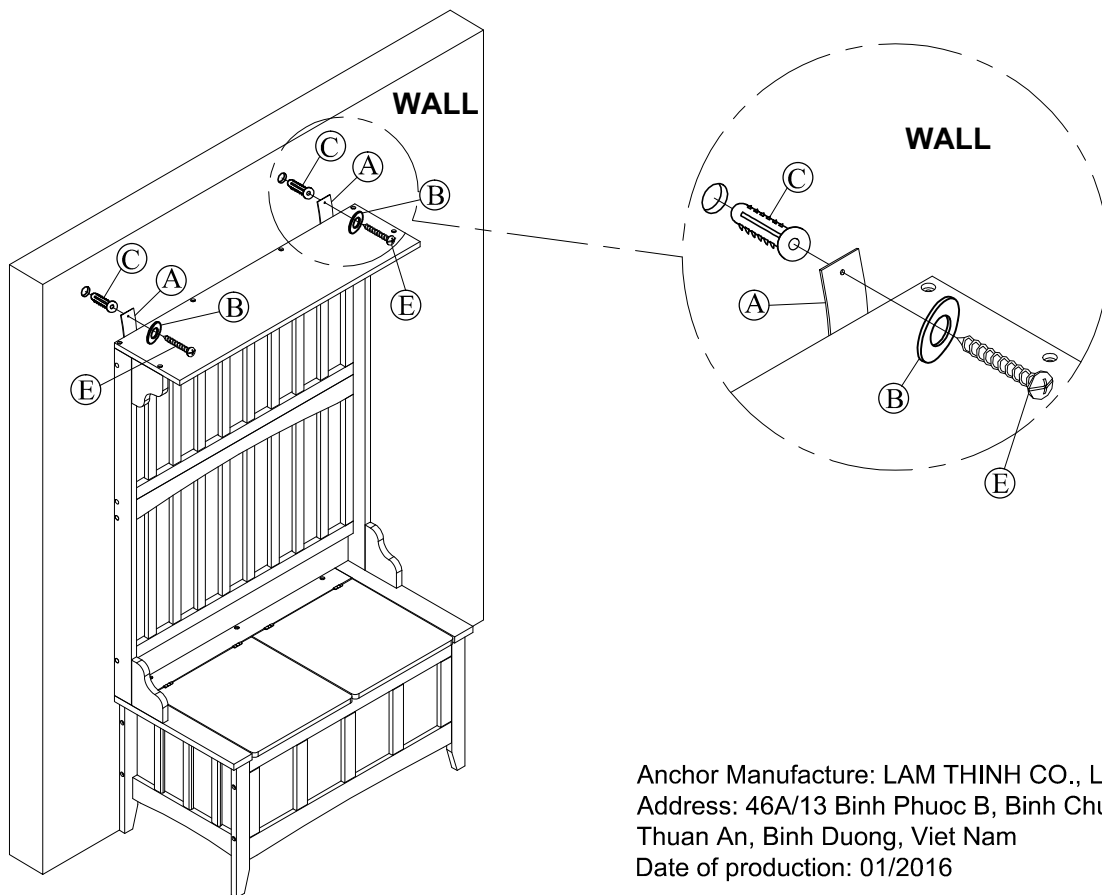

COMPLETED ASSEMBLY

